



---

**Tyco Electronics**

---

**AMP NETCONNECT  
Guide to  
ISO/IEC 11801 2<sup>nd</sup> Edition  
Including Amendment 1**

**February 2008**

By Allan Nielsen

---

A publication of Tyco Electronics



## Table of Contents

<b>SUMMARY OF CHANGES:</b> .....	<b>2</b>
<b>1. INTRODUCTION</b> .....	<b>3</b>
<b>2. CONFORMANCE</b> .....	<b>4</b>
<b>3. STRUCTURE</b> .....	<b>5</b>
<b>4. FUNCTIONAL ELEMENTS</b> .....	<b>7</b>
<b>5. CHANNEL PERFORMANCE</b> .....	<b>9</b>
<b>Twisted Pair Cabling (Balanced Cabling)</b> .....	9
Class D: .....	9
Class E: .....	10
Class E <sub>A</sub> : .....	10
Class F: .....	11
Class F <sub>A</sub> : .....	12
<b>Fibre Optic Cabling</b> .....	13
<b>6. CONNECTING HARDWARE AND CABLE</b> .....	<b>14</b>
<b>Twisted Pair Cabling (Balanced Cabling)</b> .....	14
<b>Fibre Optic Cabling</b> .....	17
<b>7. MEASUREMENT OF PERMANENT LINK AND CHANNELS</b> .....	<b>19</b>
<b>Campus Backbone or Building Backbone cabling subsystems:</b> .....	20
Twisted Pair Cabling (Balanced Cabling).....	20
Fibre Optic Cabling .....	20
<b>Horizontal Cabling Subsystem:</b> .....	21
Twisted Pair Cabling (Balanced Cabling).....	21
Fibre Optic Cabling .....	22
<b>8. REFERENCE STANDARDS</b> .....	<b>23</b>
<b>9. FOR MORE INFORMATION</b> .....	<b>26</b>

### Summary of changes:

- Addition of Classes E<sub>A</sub> and F<sub>A</sub> to meet requirements from IEEE 802.3an 10GBASE-T
- Change of conformance clause to reflect that the new Classes E<sub>A</sub> and F<sub>A</sub> only can be verified as channels, until amendment 2 have been published
- Change of naming for ELFEXT to Attenuation to Crosstalk ratio Far end; ACR-F and also PS ACR-F
- Change of naming for ACR to Attenuation to Crosstalk ratio Near end; ACR-N and also PS ACR-N
- Addition of Alien (exogenous) crosstalk for Classes E<sub>A</sub> and F<sub>A</sub>.
- Addition of minimum and maximum lengths for each segment of horizontal cabling
- Deletion of 6.4.11 Power Capacity
- Update of Unbalance attenuation, near-end (TCL) to make it normative up to 250 MHz for unscreened systems
- Addition of Unbalance attenuation, far-end (ELTCTL) for unscreened systems
- Addition of Coupling attenuation for screened systems

---

## 1. Introduction

The second edition of ISO/IEC 11801: Information technology - Generic cabling for customer premises was released from ISO/IEC in September 2002. The first amendment to ISO/IEC 11801:2002 was approved in September 2007, and contains the new requirements for Class E<sub>A</sub> and Class F<sub>A</sub>. The standard is at first sight very complex and not easy to understand.

This Guide is to help you to understand the key issues of the standard and to install your cabling in accordance with ISO/IEC 11801 2<sup>nd</sup> Edition, including Amendment 1.

The abstract of the standard reads:

Within customer premises, the importance of the cabling infrastructure is similar to that of other fundamental building utilities such as heating, lighting and mains power. As with other utilities, interruptions to service can have a serious impact. Poor quality of service due to lack of design foresight, use of inappropriate components, incorrect installation, poor administration or inadequate support can threaten an organization's effectiveness.

Historically, the cabling within premises comprised both application specific and multipurpose networks. The original edition of this standard enabled a controlled migration to generic cabling and the reduction in the use of application-specific cabling. This second edition of ISO/IEC 11801 has been developed to reflect the increased demands and opportunities which have arisen since -- and are partly the result of -- publication of the first edition in 1995.

The full standard can be bought at <http://www.iec.ch> or at your local national standardization office. Please contact your local AMP NETCONNECT office for further information.

## 2. Conformance

In order to conform to the standard you need to either:

1. Build a Channel, using connecting hardware and cable as specified by the document. E.g. Category 6 connecting hardware measured with the correct method (De-Embedded) and Category 6 cables in accordance with the cable document IEC 61156-5 and the additional requirements described in ISO/IEC 11801 2<sup>nd</sup> Edition.
2. Build a Permanent Link, using connecting hardware and cable as specified by the document. E.g. Category 6 connecting hardware measured with the correct method (De-Embedded) and Category 6 cables in accordance with the cable document IEC 61156-5 and the additional requirements described in ISO/IEC 11801 2<sup>nd</sup> Edition.
3. For Classes E<sub>A</sub> and F<sub>A</sub> conformance can only be achieved by option 1 above, until Amendment 2 of ISO/IEC 11801:2002 have been published. Permanent Link cannot be measured before component values, contained in Amendment 2, have been approved and published.

The conformance clause of the standard is the most important clause because it shows you the routes that you can use in order to build cabling which is compliant to the requirements of the standard.

If you build a channel of manufacturer specific components, for instance an old manufacturer specific Class E product line, which is not Category 6 components, but still meet the channel requirements, then you are not in accordance with the requirements of the standard. This requirement has been made to ensure the End-user has the optimum interface to the cabling and to ensure that components are available from multiple sources with both mechanical and electrical compatibility. This cannot be achieved for Classes E<sub>A</sub> and F<sub>A</sub> before component specifications have been agreed and published, until then all systems sold as being compliant to the standard are manufacturer specific cablings.

### 3. Structure

The structure of the standard is a pyramid construction, where cable connections going from central points such as the Campus Distributor reach out to the next level of distributors. Distributors may be combined in order to save space or equipment, so a campus distributor may also contain the function of a building distributor or even a floor distributor.

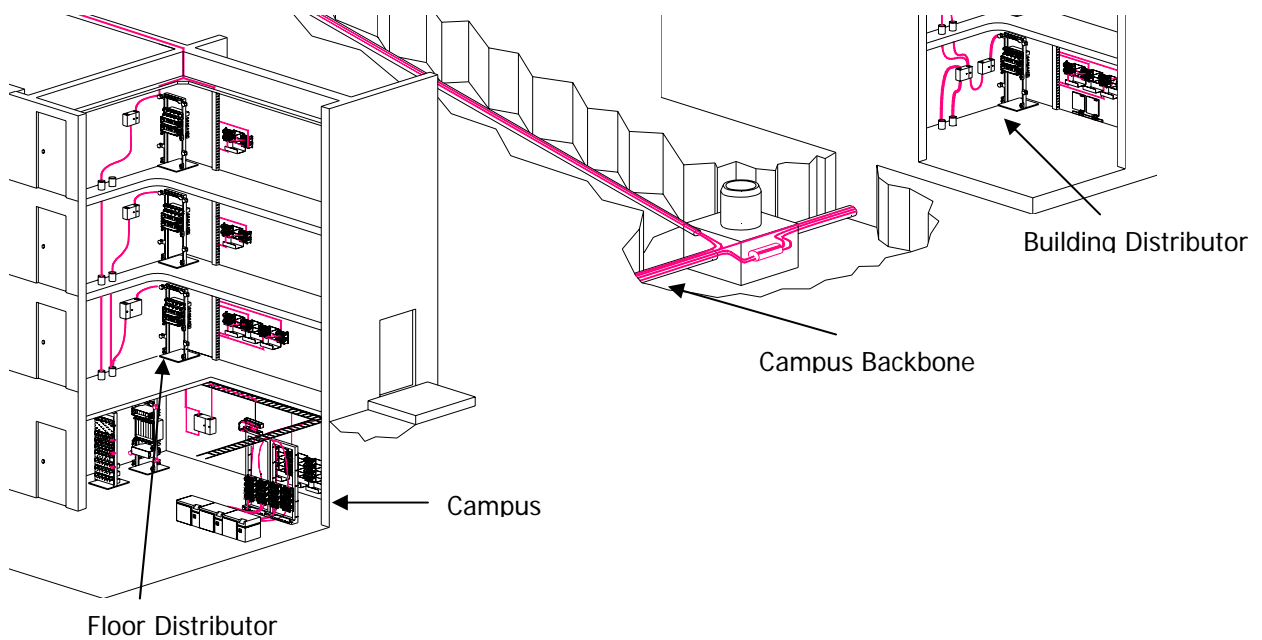

Figure 1. Structure of a cabling system

The maximum configuration of the structure is shown in figure 2.

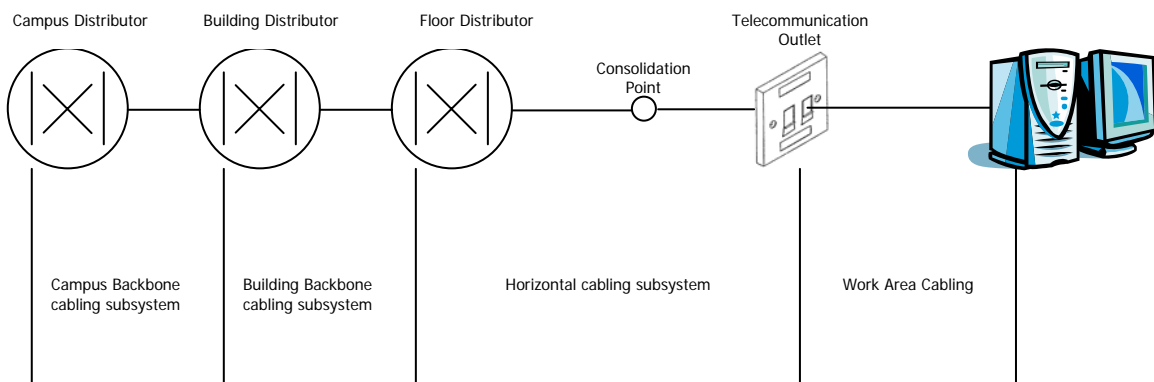

Figure 2. Maximum configuration

One overlooked element that always needs to be included is the Building Entrance Facilities, to separate outside cables from inside cables. This is in order to meet local fire regulations and to serve as a point of transient protection.

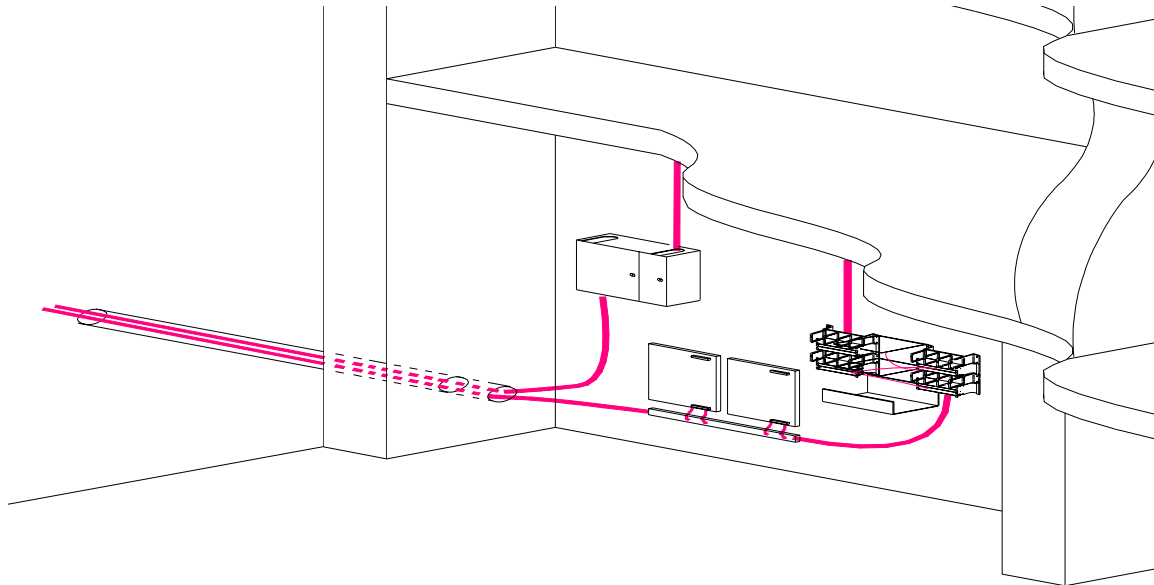

Figure 3. Building Entrance Facilities

The horizontal subsystem consists of the Floor Distributor and an optional Consolidation Point together with the Telecommunication Outlet. The Telecommunication Outlet shall be of a Categorized type of connecting hardware in order to be conformant to the standard. If other interfaces are installed, the cabling is outside the specifications of the standard and consequently a manufacturer specific cabling.

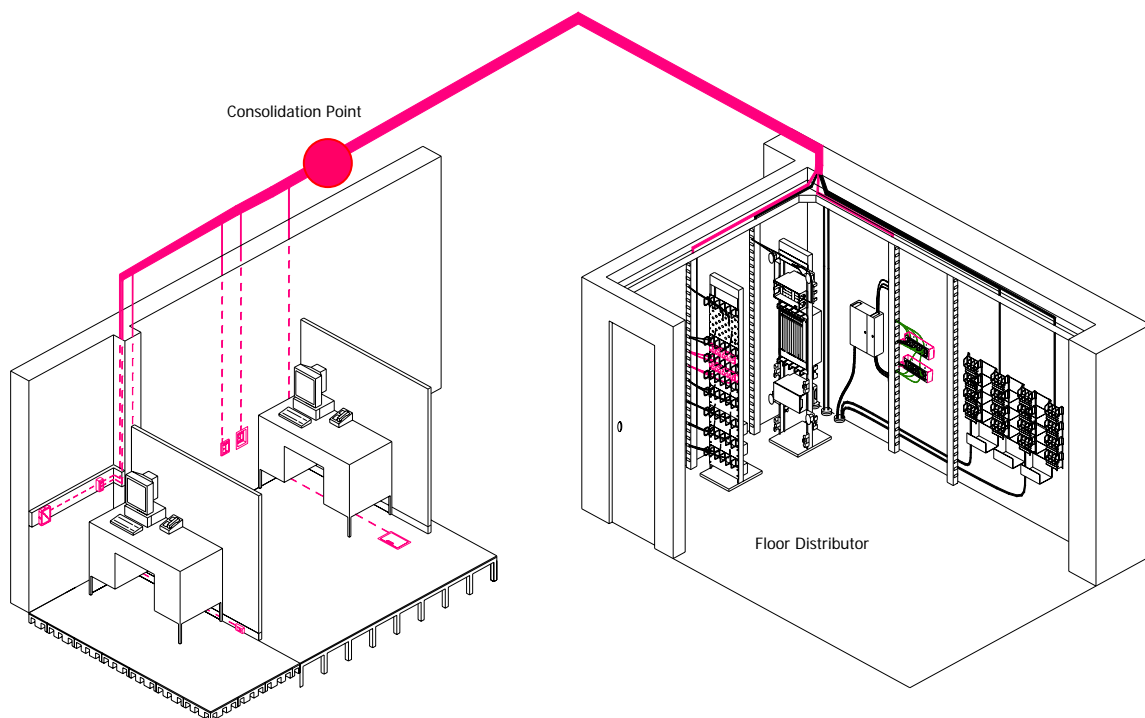

Figure 4. Horizontal Cabling

---

## 4. Functional Elements

The standard is divided into several functional elements, which all have a function. Not all functional elements are needed to form a generic cabling structure, but the most basic ones must always be there; that is the Floor distributor and the Telecommunication Outlet which form the simplest implementation of the horizontal cabling subsystem.

The functional elements of a generic cabling system are as follows:

1. Campus Distributor, which is the central point from where the campus backbone fans out, this can either be a single wiring closet, multiple wiring closets, a room or it can be combined with a building distributor. It is not recommended to combine a floor distributor with a campus distributor since it would create an unwanted structure.
2. Campus Backbone Cable, which is the communication cable including connecting hardware at both ends and jumpers or cords at the campus distributor, that connects the campus distributor with the building distributor; it can either be copper or fibre optic. If the cable is routed outside the building, it is always recommended to use fibre optic cables due to the risk of transients caused by lightning. Remember that all transients / lightnings are routed towards ground which is the medium which also contains our communication cables. Any cabling and connecting hardware in the building entrance facilities are included in the Campus Backbone Cable.
3. Building distributor, which is the central point in a building from where the building backbone fans out, is either a single wiring closet, multiple closets, a room or it can be combined with a floor distributor.
4. Building Backbone Cable, which is the communication cable including connecting hardware at both ends and jumpers or patch cords in the building distributor, connects the building distributor with the floor distributor; it can either be copper or fibre optic.
5. Floor Distributor, which is the central point at a floor from where the horizontal cabling fans out, is either a single wiring closet, multiple closets or a room.
6. Horizontal Cable, which is the communication cable including connecting hardware at both ends and jumpers or patch cords in the floor distributor, connects the floor distributor with the telecommunication outlet, it can either be copper or fibre optic.
7. Consolidation Point, which is the central point in a room from where the consolidation point cables fan out, is a small box or a minor wiring closet. It's not recommended to handle more than 12 workplaces from one consolidation point. A consolidation point shall be located at least 15 metres (cable length) away from the floor distributor in order to minimize disturbances from either elements.

8. Telecommunication Outlet, which is the interface to the generic cabling structure, can either be mounted in a raise way, in a trunk or at the wall. The outlet should be located in a user accessible location.
9. Multi-user Telecommunication Outlet, which is a grouping of Telecommunication Outlets; it is not recommended that a MUTO serves more than 12 work areas and it shall be located in an open work area so that each work area group is served by at least one MUTO.

These functional elements can be combined with both copper and fibre optic. A single work area shall be served by at least two Telecommunications outlets; the first outlet should be 4 pair twisted pair terminated at the connecting hardware chosen for this installation, e.g. Category 6, the second outlet may be for two optical fibres terminated at the SC Fibre Optic connecting hardware or 4 pair twisted pair terminated at the connecting hardware chosen for this installation.

For twisted pair installations, 2 pairs per telecommunication outlet may be used by the means of inserts, e.g. AMP Communication Outlets with dual inserts.



## 5. Channel Performance

### Twisted Pair Cabling (Balanced Cabling)

The channel performance of balanced cabling shall meet or exceed the following requirements for Class D, Class E, Class E<sub>A</sub>, Class F and Class F<sub>A</sub> channels respectively, as stated in the tables below.

All values below are derived from formulae that give a value at any frequency across the frequency range of the channel. These formulae can be found in clause 6 of the standard document ISO/IEC 11801 2<sup>nd</sup> Edition, including Amendment 1.

The tables below shall be considered as informative, while the formulae in the standard are the normative requirement.

Pair to pair NEXT, ACR-N and ACR-F are normative, but not quoted here. All power sum values are derived from pair to pair performance.

#### Class D:

Frequency MHz	Attenuation	PS NEXT	PS ACR-N	PS ACR-F	Return Loss	Coupling Attenuation	PS ANEXT	PS AACR-F	Propagation delay	Delay Skew	Unbalance Attenuation
MHz	dB	dB	dB	dB	dB	dB	dB	dB	us	us	dB
1	4,0	60,3	56,3	54,4	17,0	NA	-	-	0,580	0,050	40,0
4	4,5	50,5	46,0	42,4	17,0	NA	-	-	0,562	0,050	40,0
10	7,2	44,0	36,8	34,4	17,0	NA	-	-	0,555	0,050	38,0
16	9,1	40,6	31,5	30,3	17,0	NA	-	-	0,553	0,050	34,9
20	10,2	39,0	28,8	28,4	17,0	NA	-	-	0,552	0,050	33,5
31	12,8	35,8	22,9	24,6	15,1	50,2	-	-	0,550	0,050	30,5
62	18,5	30,6	12,1	18,6	12,1	44,2	-	-	0,549	0,050	24,5
100	24,0	27,1	3,1	14,4	10,0	40,0	-	-	0,548	0,050	20,3

**Class E:**

Frequency MHz	Attenuation	PS NEXT	PS ACR-N	PS ACR-F	Return Loss	Coupling Attenuation	PS ANEXT	PS AACR-F	Propagation delay	Delay Skew	Unbalance Attenuation
MHz	dB	dB	dB	dB	dB	dB	dB	dB	us	us	dB
1	4,0	62,0	58,0	60,3	19,0	NA	-	-	0,580	0,050	40,0
4	4,2	60,5	56,4	48,2	19,0	NA	-	-	0,562	0,050	40,0
10	6,6	54,0	47,4	40,3	19,0	NA	-	-	0,555	0,050	38,0
16	8,3	50,6	42,3	36,2	18,0	NA	-	-	0,553	0,050	34,9
20	9,3	49,0	39,7	34,2	17,5	NA	-	-	0,552	0,050	33,5
31	11,7	45,8	34,1	30,4	16,5	50,2	-	-	0,550	0,050	30,5
62	16,8	40,6	23,8	24,4	14,1	44,2	-	-	0,549	0,050	24,5
100	21,7	37,1	15,4	20,3	12,0	40,0	-	-	0,548	0,050	20,3
125	24,5	35,4	10,9	18,3	11,0	38,1	-	-	0,547	0,050	18,4
155	27,6	33,8	6,2	16,5	10,1	36,2	-	-	0,547	0,050	16,5
175	29,5	32,9	3,4	15,4	9,6	35,1	-	-	0,547	0,050	15,4
200	31,7	31,9	0,1	14,2	9,0	34,0	-	-	0,547	0,050	14,3
250	35,9	30,2	-5,8	12,3	8,0	32,0	-	-	0,546	0,050	12,3

**Class E<sub>A</sub>:**

Frequency MHz	Attenuation	PS NEXT	PS ACR-N	PS ACR-F	Return Loss	Coupling Attenuation	PS ANEXT	PS AACR-F	Propagation delay	Delay Skew	Unbalance Attenuation
MHz	dB	dB	dB	dB	dB	dB	dB	dB	us	us	dB
1	4,0	62,0	58,0	60,3	19,0	NA	67,0	67,0	0,580	0,050	40,0
4	4,2	60,5	56,4	48,2	19,0	NA	67,0	65,0	0,562	0,050	40,0
10	6,5	54,0	47,5	40,3	19,0	NA	67,0	57,0	0,555	0,050	38,0
16	8,2	50,6	42,4	36,2	18,0	NA	67,0	52,9	0,553	0,050	34,9
20	9,2	49,0	39,8	34,2	17,5	NA	67,0	51,0	0,552	0,050	33,5
31	11,4	45,8	34,3	30,4	16,5	50,2	65,1	47,2	0,550	0,050	30,5
62	16,3	40,6	24,3	24,4	14,1	44,2	62,1	41,2	0,549	0,050	24,5
100	20,9	37,1	16,2	20,3	12,0	40,0	60,0	37,0	0,548	0,050	20,3
125	23,5	35,4	11,9	18,3	11,0	38,1	58,5	35,1	0,547	0,050	18,4
155	26,3	33,8	7,5	16,5	10,1	36,2	57,1	33,2	0,547	0,050	16,5
175	28,0	32,9	4,8	15,4	9,6	35,1	56,4	32,1	0,547	0,050	15,4
200	30,1	31,9	1,8	14,2	9,0	34,0	55,5	31,0	0,547	0,050	14,3
250	33,9	30,2	-3,7	12,3	8,0	32,0	54,0	29,0	0,546	0,050	12,3
300	37,4	28,8	-8,6	10,7	7,2	30,5	52,8	27,5	0,546	0,050	FFS
400	43,7	26,6	-17,1	8,2	6,0	28,0	51,0	25,0	0,546	0,050	FFS
500	49,3	24,8	-24,5	6,3	6,0	26,0	49,5	23,0	0,546	0,050	FFS

**Class F:**

Frequency MHz	Attenuation	PS NEXT	PS ACR-N	PS ACR-F	Return Loss	Coupling Attenuation	PS ANEXT	PS AACR-F	Propagation delay	Delay Skew	Unbalance Attenuation
MHz	dB	dB	dB	dB	dB	dB	dB	dB	us	us	dB
1	4,0	62,0	58,0	62,0	19,0	NA	-	-	0,580	0,030	40,0
4	4,1	62,0	57,9	62,0	19,0	NA	-	-	0,562	0,030	40,0
10	6,4	62,0	55,6	57,8	19,0	NA	-	-	0,555	0,030	38,0
16	8,1	62,0	53,9	54,5	18,0	NA	-	-	0,553	0,030	34,9
20	9,1	62,0	52,9	52,9	17,5	NA	-	-	0,552	0,030	33,5
31	11,3	62,0	50,7	49,8	16,5	50,2	-	-	0,550	0,030	30,5
62	16,2	62,0	45,8	44,9	14,1	44,2	-	-	0,549	0,030	24,5
100	20,8	59,9	39,1	41,4	12,0	40,0	-	-	0,548	0,030	20,3
125	23,4	58,4	35,0	39,8	11,0	38,1	-	-	0,547	0,030	18,4
155	26,2	57,0	30,8	38,3	10,1	36,2	-	-	0,547	0,030	16,5
175	27,9	56,2	28,3	37,4	9,6	35,1	-	-	0,547	0,030	15,4
200	30,0	55,3	25,4	36,4	9,0	34,0	-	-	0,547	0,030	14,3
250	33,8	53,9	20,1	34,8	8,0	32,0	-	-	0,546	0,030	12,3
300	37,3	52,7	15,4	33,4	8,0	30,5	-	-	0,546	0,030	FFS
400	43,6	50,8	7,2	31,3	8,0	28,0	-	-	0,546	0,030	FFS
500	49,3	49,4	0,1	29,6	8,0	26,0	-	-	0,546	0,030	FFS
600	54,6	48,2	-6,4	28,3	8,0	24,4	-	-	0,545	0,030	FFS

**Class F<sub>A</sub>:**

Frequency MHz	Attenuation	PS NEXT	PS ACR-N	PS ACR-F	Return Loss	Coupling Attenuation	PS ANEXT	PS AACR-F	Propagation delay	Delay Skew	Unbalance Attenuation
MHz	dB	dB	dB	dB	dB	dB	dB	dB	us	us	dB
1	4,0	62,0	58,0	62,0	19,0	NA	67,0	67,0	0,580	0,030	40,0
4	4,1	62,0	57,9	62,0	19,0	NA	67,0	67,0	0,562	0,030	40,0
10	6,4	62,0	55,6	62,0	19,0	NA	67,0	67,0	0,555	0,030	38,0
16	8,0	62,0	54,0	60,3	18,0	NA	67,0	67,0	0,553	0,030	34,9
20	9,0	62,0	53,0	58,4	17,5	NA	67,0	66,0	0,552	0,030	33,5
31	11,2	62,0	50,8	54,6	16,5	50,2	67,0	62,2	0,550	0,030	30,5
62	15,9	62,0	46,1	48,5	14,1	44,2	67,0	56,2	0,549	0,030	24,5
100	20,3	62,0	41,7	44,4	12,0	40,0	67,0	52,0	0,548	0,030	20,3
125	22,7	61,7	39,0	42,5	11,0	38,1	67,0	50,1	0,547	0,030	18,4
155	25,4	60,0	34,6	40,6	10,1	36,2	67,0	48,2	0,547	0,030	16,5
175	27,0	59,0	32,0	39,5	9,6	35,1	67,0	47,1	0,547	0,030	15,4
200	28,9	57,9	29,0	38,4	9,0	34,0	67,0	46,0	0,547	0,030	14,3
250	32,5	56,1	23,7	36,4	8,0	32,0	67,0	44,0	0,546	0,030	12,3
300	35,7	54,7	19,0	34,8	8,0	30,5	67,0	42,5	0,546	0,030	FFS
400	41,5	52,4	10,9	32,3	8,0	28,0	66,0	40,0	0,546	0,030	FFS
500	46,7	50,6	3,9	30,4	8,0	26,0	64,5	38,0	0,546	0,030	FFS
600	51,4	49,1	-2,3	28,8	8,0	24,4	63,3	36,4	0,545	0,030	FFS
1000	67,6	44,9	-22,6	24,4	6,0	20,0	60,0	32,0	0,545	0,030	FFS

All channels are based on the maximum of 4 set of connectors.

In amendment 1 of ISO/IEC 11801 2<sup>nd</sup> Edition a minimum length has been added to ensure Alien Crosstalk performance for balanced cabling channels:

Segment	Minimum	Maximum
Floor Distributor to Consolidation Point	15	85
Consolidation Point to Telecommunication Outlet	5	-
Floor Distributor to Telecommunication Outlet	15	90
Work area cord <sup>1</sup>	2	5
Patch cord	2	-
Equipment cord <sup>2</sup>	2	5
All cords	-	10

Note 1: If there is no Consolidation Point, the minimum length of the work area cord is 1 metre.

Note 2: If there is no cross-connect, the minimum length of the equipment cord is 1 metre.

Please consult the manufacturer of the cabling system for shorter length support, e.g. this can be done with an AMP NETCONNECT XG screened cabling system, supporting link lengths down to 5 metres.

If a screened system is used for Class E<sub>A</sub> and Class F<sub>A</sub>, then Alien Crosstalk is met by design; this means that channel verification of Alien Crosstalk (PS ANEXT and PS AACR-F) is unnecessary, due to the superior performance of shielded systems.

Unscreened Class E<sub>A</sub> channels need to have Alien Crosstalk verified in order to meet the standard, regardless of manufacturer's warranty. This can be achieved by complex measurement technologies developed by manufacturers of field testing equipment.

## Fibre Optic Cabling

The channel performance of fibre optic cabling shall exceed the following requirements for OF-300, OF-500 and OF-2000 channels respectively, as stated in the table below.

Channel Attenuation				
dB				
Channel	Multimode		Singlemode	
	850 nm	1300 nm	1310 nm	1550 nm
OF-300	2,55	1,95	1,80	1,80
OF-500	3,25	2,25	2,00	2,00
OF-2000	8,50	4,50	3,50	3,50

All channels are based on the maximum of:

- 300, 500 or 2000 metre of fibre optic cable
- 2 mated connections (1,5 dB allocation)

The three optical fibre channels are defined as:

- OF-300: A channel that supports applications over the optical fibre types referenced in the cable clause to a minimum of 300 metres.
- OF-500: A channel that supports applications over the optical fibre types referenced in the cable clause to a minimum of 500 metres.
- OF-2000: A channel that supports applications over the optical fibre types referenced in the cable clause to a minimum of 2000 metres.

Care shall be taken to ensure that fibre types of different physical construction, defined as the core and cladding diameter and numerical aperture (bandwidth), are not mixed within a channel. Mixing of different fibre types may result in degradation of the fibre optical channel performance.

## 6. Connecting Hardware and Cable

### Twisted Pair Cabling (Balanced Cabling)

Connecting hardware and Cable are the building blocks that you use to create your cabling. In the standard these are called components. The choice of components is important to both the installer and the end user, not only because of the price and delivery performance of different manufacturers, but also because of the total cabling channel performance.

In ISO/IEC 11801 2<sup>nd</sup> Edition you can find the following text:

#### **Horizontal cabling - Component choice**

The selection of balanced cabling components will be determined by the class of applications to be supported. Refer to Annex F for guidance.

Using the configurations of 7.2.2.2:

- Category 5 components provide Class D balanced cabling performance;
- Category 6 components provide Class E balanced cabling performance;
- Category 6<sub>A</sub> components provide Class E<sub>A</sub> balanced cabling performance;
- Category 7 components provide Class F balanced cabling performance;
- Category 7<sub>A</sub> components provide Class F<sub>A</sub> balanced cabling performance.

Cables and connecting hardware of different categories may be mixed within a channel; however the resultant cabling performance will be determined by the category of the lowest performing component."

Class E<sub>A</sub> and Class F<sub>A</sub> channels are, until Amendment 2 of ISO/IEC 11801 2<sup>nd</sup> Edition is published, manufacturer specific. Category 6<sub>A</sub> and Category 7<sub>A</sub> connecting hardware and cable specifications are subject to new measurement methods for components, and performance are expected to be published during 2009.

Only channel performance of Class E<sub>A</sub> and Class F<sub>A</sub> can be verified in accordance with this standard, until Amendment 2 of ISO/IEC 11801 2<sup>nd</sup> Edition is published.

---

The minimum performance for connecting hardware can be found in:

<b>Standard</b>	<b>Category</b>	<b>Comment</b>
IEC 60603-7-2	Category 5 UTP	Also known as TIA/EIA Category 5 Enhanced
IEC 60603-7-3	Category 5 STP	Also known as TIA/EIA Category 5 Enhanced
IEC 60603-7-4	Category 6 UTP	
IEC 60603-7-41	Category 6 <sub>A</sub> UTP	Not published yet, expected during 2009.
IEC 60603-7-5	Category 6 STP	
IEC 60603-7-51	Category 6 <sub>A</sub> STP	Not published yet, expected during 2009.
IEC 60603-7-7	Category 7 STP	RJ45 interface with switch function to alternate pair assignment
IEC 60603-7-71	Category 7 <sub>A</sub> STP	Not published yet, expected during 2009.
IEC 61076-3-104	Category 7 STP Category 7 <sub>A</sub> STP	Alternative High Performance interface, specified as 1000 MHz connector in its current version.

Category 5 and 6 standards have the De-Embedded test method as the only test method which can qualify the connecting hardware. Please see AMP NETCONNECT white paper on that subject for further information.

Category 6A and Category 7A standards are subject to new measurement methods, using direct probing and Re-Embedding techniques to verify component performance.

In the above standards the specification requires separate values for both the Modular Plug and the Modular Jack in order to have compatibility between different manufactures of connecting hardware. E.g. it should be possible to mate a Plug from AMP NETCONNECT with any other manufacturer of Jacks (Sockets) and still meet the requirements. This is not valid for Category 6<sub>A</sub> and Category 7<sub>A</sub> connecting hardware, until the component and measurement standards have been published.

For twisted Pair cabling, the only place where a standardized interface is required is at the Telecommunication Outlet. At any other point the user is free to choose any other interface meeting the transmission characteristics of the standardized interface; this is explained in detail in Annex C of ISO/IEC 11801 2<sup>nd</sup> Edition. This requires more test equipment than just a hand held tester, which means that verification has to be validated at a laboratory, either at the manufacturer or a 3<sup>rd</sup> party, before installation. The easiest implementation is to use standardized interfaces throughout the installation.

Twisted Pair cables are referenced as balanced cables in the standard, due to the possibility of making the cables with a quad. A quad is 4 wires which are twisted together to form a cable element, while most cables have a pair as the cable element.

The requirements for cable have to meet the specified IEC standards together with some additional requirements, specified in ISO/IEC 11801 2<sup>nd</sup> Edition. These requirements are:

Mean Characteristic Impedance:

The nominal impedance shall be 100 Ohm. The cable standards allow both 100 and 120 Ohm, but a 120 Ohm cable would make it impossible to create a channel without return loss problems.

Attenuation:

There are two types of Category 5 cables, one specified by ISO/IEC and one specified by TIA/EIA. The difference between these two cables is a little higher attenuation on the TIA/EIA. Usage of the TIA/EIA cable is not allowed by ISO/IEC 11801 2<sup>nd</sup> edition.

The minimum performance of twisted pair cables can be found in:

<b>Standard</b>	<b>Specification</b>	<b>Comment</b>
IEC 61156-2 (2007)	Sectional Specification for multicore and symmetrical pair/quad cables for digital communications – Horizontal wiring	General requirements
IEC 61156-3 (2007)	Sectional Specification for multicore and symmetrical pair/quad cables for digital communications – Work area wiring	General requirements
IEC 61156-4 (2007)	Sectional Specification for multicore and symmetrical pair/quad cables for digital communications – Riser cables	General requirements
IEC 61156-5 (2007)	Symmetrical pair/quad cables for digital communications with transmission characteristics up to 600 MHz – Part 5: Horizontal wiring	Performance requirements
IEC 61156-6 (2007)	Symmetrical pair/quad cables for digital communications with transmission characteristics up to 600 MHz – Part 6: Work area wiring	Performance requirements



## Fibre Optic Cabling

The minimum performance of fibre optic connecting hardware can be found in:

Standard	Specification	Requirements
IEC 60874-19-1	SC Duplex Fibre Optic patch cord connector type SC-PC (floating duplex)	Optical, mechanical and environmental
IEC 60874-19-2	SC Duplex Fibre Optic adaptor for singlemode fibre	Optical, mechanical and environmental
IEC 60874-19-3	SC Duplex Fibre Optic adaptor for multimode fibre	Optical, mechanical and environmental

For Fibre Optic cabling the only place where the above standardized interface is required is at the Telecommunication Outlet. At any other place the user is free to choose any other interface which is standardized by IEC and meets the optical and environmental requirements of an SC Duplex connector. Connecting hardware of the types MU, MT-RJ and LC meets these requirements. Please note that ST connectors are not allowed by the standard any more, due to the environmental and optical performance of this interface.

The attenuation of fibre optic connecting hardware is based on a statistical value. An example:

- If you have 200 connectors and mate them to 100 mated connectors, then you will have a range of attenuations within the connector groups. This range will go from 0,1 to 0,75 dB where most connections will be around 0,3 dB.
- The average attenuation will not change if you rearrange the mating of the connectors.
- One connector mated with 100 other connectors will have the attenuation range from 0,1 to 0,75 dB, but 0,3 in average.

The maximum attenuation performance of a fibre optic cable shall be:

Maximum Cable Attenuation				
DB/km				
Wavelength	OM1, OM2 and OM3 Multimode		OS1 Singlemode	
	850 nm	1300 nm	1310 nm	1550 nm
Attenuation	3,5	1,5	1,0	1,0

The minimum bandwidth of a fibre optic cable shall be:

<b>Minimum modal bandwidth</b>				
<b>MHz - km</b>				
<b>Wavelength</b>		<b>Overfilled Launch Bandwidth</b>		<b>Effective Laser Launch Bandwidth</b>
		<b>850 nm</b>	<b>1300 nm</b>	<b>850 nm</b>
<b>Optical fibre type</b>	<b>Core diameter in <math>\mu\text{m}</math></b>			
<b>OM1</b>	50 or 62,5	200	500	Not specified
<b>OM2</b>	50 or 62,5	500	500	Not specified
<b>OM3</b>	50	1500	500	2000

Multimode Optical fibre shall comply to the following standards:

<b>Standard</b>	<b>Specification</b>	<b>Comment</b>
IEC 60793-2-10	Multimode fibre optic standard type A1a equal to 50/125 $\mu\text{m}$	This standard specifies a range of bandwidths; ISO/IEC has specified the exact minimum values for this cable type.
IEC 60793-2-10	Multimode fibre optic standard type A1b equal to 62,5/125 $\mu\text{m}$	This standard specifies a range of bandwidths; ISO/IEC has specified the exact minimum values for this cable type.
IEC 60793-2-50	Singlemode fibre optic standard type B1 equal to 9/125 $\mu\text{m}$	Furthermore the fibre shall meet ITU-T G.652.
IEC 60794-2	Indoor mechanical and environmental requirements	General requirements.
IEC 60794-3	Outdoor mechanical and environmental requirements	General requirements.

## 7. Measurement of Permanent Link and Channels

In order to measure Permanent Links or Channels in accordance with ISO/IEC 11801 2<sup>nd</sup> edition, you need to understand the building blocks that you can use, please refer to the Structure clause of this document for further information.

The three different subsystems of a structured cabling shall be measured separately, either as 1: a Permanent Link which consists of the connecting hardware and cables that are permanent. An example is:

- A Horizontal Link spanning from the first patch panel at the floor distributor to the telecommunication outlet, including an optional consolidation point. Patch cords and jumpers are not included.
- A Horizontal Link spanning from the first patch panel at the floor distributor to the consolidation point connector. Patch cord and jumpers are not included.

Or 2: a channel which is like the above, only including patch cords and jumpers. Class E<sub>A</sub> and Class F<sub>A</sub> can only be verified as channels, until Amendment 2 of ISO/IEC 11801 2<sup>nd</sup> Edition have been published.

The following examples show the different ways of implementing a Permanent Link or a Channel, in either a backbone or a horizontal cabling subsystem:

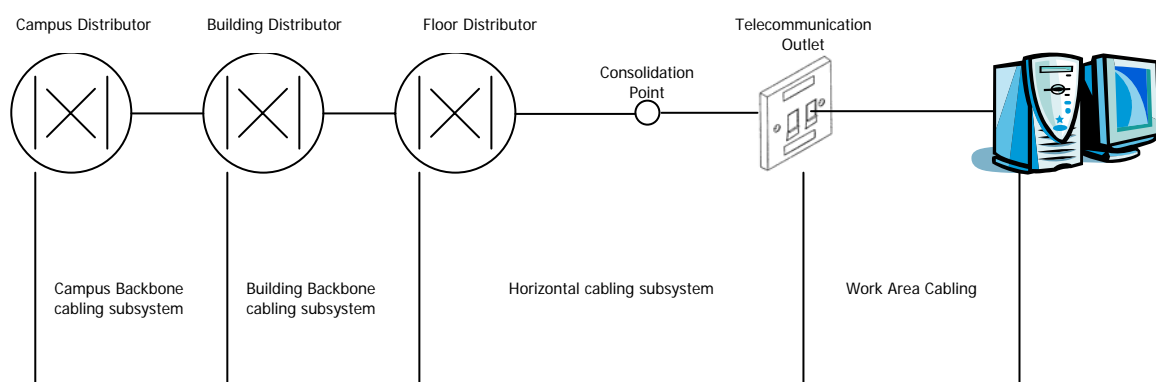

## Campus Backbone or Building Backbone cabling subsystems:

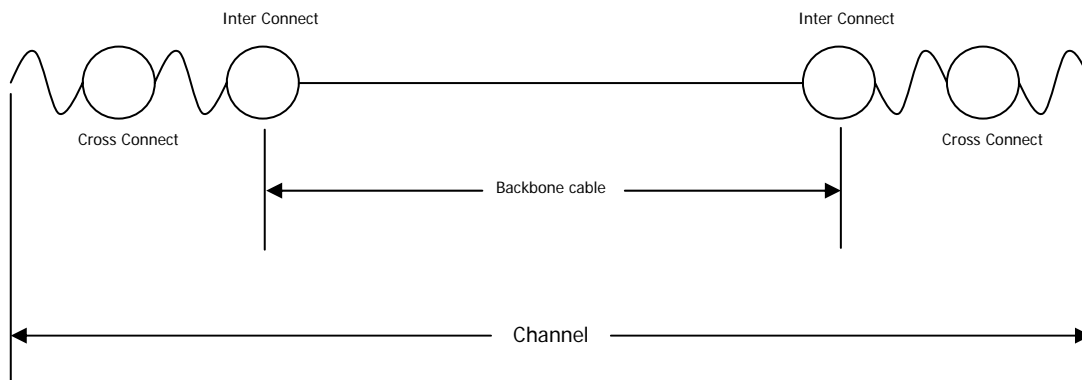

### Twisted Pair Cabling (Balanced Cabling)

A Channel measurement includes all patch cords and jumpers and span from the ends of the channel. The measurement equipment limits shall be set to "ISO/IEC 11801 2<sup>nd</sup> Edition, Amendment 1 Class A, Class B, Class C, Class D, Class E, Class E<sub>A</sub>, Class F or Class F<sub>A</sub> channel" settings. If applicable for the tester, the values shall include 4 connections.

A Link does not include any patch cords and jumpers and span from the interconnect in each side of the installed cable. When measuring backbone systems, the measurement equipment limits shall be set to "ISO/IEC 11801 2<sup>nd</sup> Edition, Amendment 1 Class A, Class B, Class C, Class D, Class E or Class F Link" settings. If applicable for the tester the values shall include 2 connections.

### Fibre Optic Cabling

Channel measurement includes all patch cords and jumpers, and span from the ends of the channel. The power budget shall include up to 4 mated connections and the given amount of installed cable for OF-300, OF-500 or OF-2000 respectively.

A Link does not include any patch cords and jumpers, and span from the interconnect in each side of the installed cable. When measuring backbone systems, the power budget shall include 2 mated connections and the given amount of installed cable for OF-300, OF-500 or OF-2000 respectively.

When measuring Fibre Optic Cabling systems, a mandrel wrap shall be used on the launch fibre. The function of a mandrel wrap is to remove any unwanted modes (light signals), in the reference cords and in the installation, under measurement.

ISO/IEC 14763-3 specifies usage of reference connectors, which are controlled end face connectors with a very low attenuation, when measuring fibre optic channels or links. These measurement kits can be found in the AMP NETCONNECT product catalogue.

---

Usage of standard fibre optic patch cords will reduce the accuracy of measurement for fibre optic links or channels.

### Horizontal Cabling Subsystem:

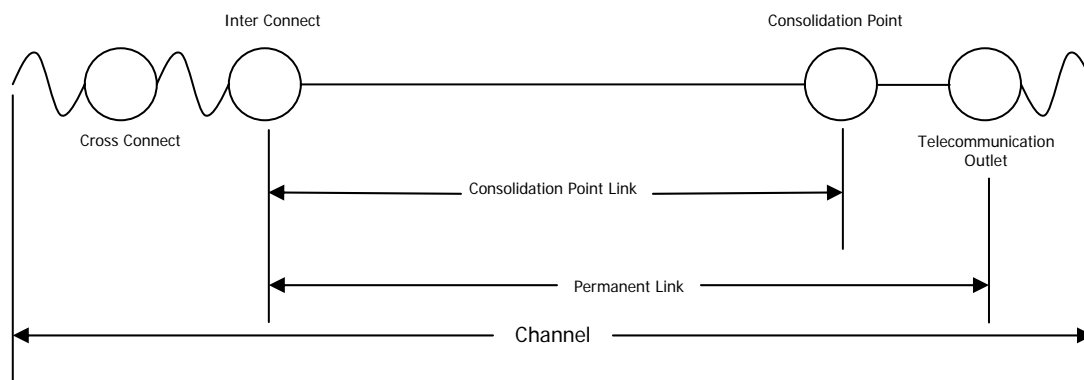

### Twisted Pair Cabling (Balanced Cabling)

A Channel measurement includes all patch cords and jumpers, and span from the ends of the channel. The measurement equipment limits shall be set to "ISO/IEC 11801 2<sup>nd</sup> Edition Amendment 1 Class D, Class E, Class E<sub>A</sub>, Class F or Class F<sub>A</sub> channel" settings. If applicable for the tester, the values shall include 4 connections.

A Link does not include any patch cords and jumpers, and span from the interconnect at the Floor Distributor to either the Consolidation Point or to the Telecommunication Outlet. When measuring horizontal systems, the measurement equipment limits shall be set to "ISO/IEC 11801 2<sup>nd</sup> Edition Amendment 1 Class D, Class E or Class F Permanent Link" settings.

Class E<sub>A</sub> and Class F<sub>A</sub> can only be verified as channels until Amendment 2 of ISO/IEC 11801 2<sup>nd</sup> Edition is published.

Some measurement equipment can be configured to either a 2 connector Permanent Link, or a 3 connector Permanent Link. These options shall be used:

- When measuring a Consolidation Point Link, the measurement equipment shall be configured to a 2 connector Permanent Link.
- When measuring a Permanent Link without a Consolidation Point, the measurement equipment shall be configured to a 2 connector Permanent Link.
- When measuring a Permanent Link with a Consolidation Point, the measurement equipment shall be configured to a 3 connector Permanent Link.

For further information on approved measurement equipment and configuration options, please contact your local AMP NETCONNECT office.

### **Fibre Optic Cabling**

Channel measurement includes all patch cords and jumpers, and span from the ends of the channel. The power budget shall include up to 4 mated connections and the given amount of installed cable for OF-300, OF-500 or OF-2000 respectively.

A Link does not include any patch cords and jumpers, and span from the interconnect in the Floor Distributor to the Consolidation Point or the Telecommunication Outlet. When measuring horizontal systems the power budget shall include 2 or 3 mated connections and the given amount of installed cable for OF-300, OF-500 or OF-2000 respectively.

Some measurement equipment can be configured to either a 2 connector Permanent Link, or a 3 connector Permanent Link. These options shall be used:

- When measuring a Consolidation Point Link, the measurement equipment shall be configured to a 2 connector Permanent Link.
- When measuring a Permanent Link without a Consolidation Point, the measurement equipment shall be configured to a 2 connector Permanent Link.
- When measuring a Permanent Link with a Consolidation Point, the measurement equipment shall be configured to a 3 connector Permanent Link.

Further information on approved measurement equipment and configuration options can be acquired at your local AMP NETCONNECT office.

When measuring Fibre Optic Cabling systems, a mandrel wrap shall be used on the launch fibre. The function of a mandrel wrap is to remove any unwanted modes (light signals), in the reference cords and in the installation, under measurement.

ISO/IEC 14763-3 specifies usage of reference connectors, which are controlled end face connectors with a very low attenuation, when measuring fibre optic channels or links. These measurement kits can be found in the AMP NETCONNECT product catalogue.

Usage of standard fibre optic patch cords will reduce the accuracy of measurement for fibre optic links or channels.

---

## 8. Reference Standards

Consultants and End-users often refer to ISO/IEC 11801 2<sup>nd</sup> edition, including Amendment 1 alone. By making this reference to a specification or a tender, the installer or system integrator also commits to compliance to the following listed standards. It is recommended for Consultants and End-users also to include the following standards in their project specification:

- IEC 60603-7:1996-11, Connectors for electronic equipment – Part 7-1: Detail specification for connectors, 8 way, shielded free and fixed connectors with common mating features, with assessed quality
- IEC 60603-7-1:2002-01, Connectors for frequencies below 3 MHz for use with printed boards – Part 7: Detail specification for connectors, 8 way, including fixed and free connectors with common mating features
- IEC 60603-7-2: Detail specification for 8 way connectors, with assessed quality, including fixed and free connectors with common mounting features; test methods and related requirements for use at frequencies up to 100 MHz
- IEC 60603-7-3: Detail specification for 8 way connectors, with assessed quality, including fixed and free connectors with common mounting features; test methods and related requirements for use at frequencies up to 100 MHz
- IEC 60603-7-4: Connectors for electronic equipment: Detail specification for an 8 way connector with performance up to 250 MHz
- IEC 60603-7-5: Detail specification for 8 way connectors, with assessed quality, including fixed and free connectors with common mounting features; test methods and related requirements for use at frequencies up to 100 MHz
- IEC 60603-7-7: 2002 Connectors for use in d.c., low frequency analogue and in digital high speed data applications - Part 7- 7: 8 way connectors for frequencies up to 600 MHz [Category 7 Detail Specification]
- IEC 60794-2: Optical fibre cables - Part 2: Product specification (indoor cable)
- IEC 60793-2-10, Optical fibres - Part 2-10: Product specifications - Sectional specification for category A1 multimode fibres
- IEC 60793-2-50, Optical fibres - Part 2-50: Product specifications - Sectional specification for class B single-mode fibres
- IEC 60794-3 (all parts): Optical fibre cables - Part 3: Sectional specification - Outdoor cables
- IEC 60825 (all parts): Safety of laser products
- IEC 60874-1:1999, Connectors for optical fibres and cables – Part 1: Generic specification
- IEC 60874-14 (all parts), Connectors for optical fibres and cables - Part 14: Sectional specification for fibre optic connector - Type SC
- IEC 60874-19 (all parts), Connectors for optical fibres and cables - Part 19: Sectional specification for fibre optic connector - Type SCD(uplex)
- IEC 60874-19-1:1999, Connectors for optical fibres and cables - Part 19-1: Fibre optic patch cord connector type SC-PC (floating duplex) standard terminated on multimode optical fibre type A1a, A1b - Detail specification
- IEC 60874-19-2:1999, Connectors for optical fibres and cables - Part 19-2: Fibre optic adaptor (duplex) type SC for single-mode fibre connectors - Detail specification
- IEC 60874-19-3,1999, Connectors for optical fibres and cables - Part 19-3: Fibre optic adaptor (duplex) type SC for multimode fibre connectors - Detail specification
- IEC 61073-1: Mechanical splices and fusion splice protection for optical fibres and cables – Part 1: Generic specification
- IEC 61076-3-104: Connectors for electronic equipment - Part 3-104: Detail specification for 8 way, shielded free and fixed connectors, for data transmission with frequencies up to 1000 MHz
- IEC 61156 (all parts), Multicore and symmetrical pair/quad cables for digital communications

- IEC 61156-1:1994, Multicore and symmetrical pair/quad cables for digital communications – Part 1: Generic specification
- IEC 61156-1 Am2: 2001-06, Amendment 2
- IEC 61156-2, Multicore and symmetrical pair/quad cables for digital communications – Part 2: Multicore and symmetrical pair/quad cables for digital communications - Part 2: Horizontal floor wiring - Sectional specification
- IEC 61156-3, Multicore and symmetrical pair/quad cables for digital communications – Part 3: Multicore and symmetrical pair/quad cables for digital communications - Part 3: Work area wiring - Sectional specification
- IEC 61156-4, Multicore and symmetrical pair/quad cables for digital communications – Part 4: Multicore and symmetrical pair/quad cables for digital communications - Part 4: Riser cables - Sectional specification
- IEC 61156-5:2002-03, Multicore and symmetrical pair/quad cables for digital communications - Part 5: Symmetrical pair/quad cables with transmission characteristics up to 600 MHz - Horizontal floor wiring - Sectional specification
- IEC 61156-6:2002-03, Multicore and symmetrical pair/quad cables for digital communications - Part 6: Symmetrical pair/quad cables with transmission characteristics up to 600 MHz - Work area wiring - Sectional specification
- IEC 61300-3-34:2001-12, Fibre optic interconnecting devices and passive components - Basic test and measurement procedures - Part 3-34: Examinations and measurements - Attenuation of random mated connectors
- IEC 61753-1-1:2000-11, Fibre optic interconnecting devices and passive components performance standard - Part 1-1: General and guidance - Interconnecting devices (connectors)
- IEC 61935-1, Generic specification for the testing of generic cabling in accordance with ISO/IEC 11801 – Part 1: Installed cabling
- IEC 61935-2: Generic cabling systems - Specification for the testing of balanced communication cabling in accordance with ISO/IEC 11801 - Part 2: Patchcord and work area cabling ISO/IEC 11801 Ed.1: 1995, Information technology - Generic cabling for customer premises
- ISO/IEC 11801 Ed.1.2: 2000, Information technology - Generic cabling for customer premises
- ISO/IEC 14763-1: Information technology - Implementation and operation of customer premises cabling - Part 1: Administration
- ISO/IEC 14763-2, Information technology - Implementation and operation of customer premises cabling - Part 2: Planning and installation
- ISO/IEC 14763-3, Information technology - Implementation and operation of customer premises cabling - Part 3: Testing of optical fibre cabling
- ITU-T Rec. G.652: 1993, Characteristics of a single-mode mode optical fibre cable

Your local AMP NETCONNECT office can make this reference list available in an electronic format.





## 9. For More Information

Please contact your local AMP NETCONNECT sales office.

**AMP NETCONNECT Phone Numbers for Europe/Middle East/Africa:**

<b>Austria</b> 43-1-90560-0	<b>Belgium</b> 32-2-719-2526	<b>Bulgaria</b> 359-2-971-2151	<b>Croatia</b> 385-1-67-04-46
<b>Czech Rep.</b> 420-5-41-162-111	<b>Denmark</b> 45-70-155-200	<b>Egypt</b> 202-419-2334	<b>Estonia</b> 372-6-505-475
<b>Finland</b> 358-9-51-234-221	<b>France</b> 33-1-34-20-8904	<b>Germany</b> 49-6103-709-1547	<b>Greece</b> 30-1-937-0396
<b>Holland</b> 32-1-635-2326	<b>Hungary</b> 36-1-289-1007	<b>Ireland</b> 353-1-820-3000	<b>Israel</b> 972-3-751-8421
<b>Italy</b> 39-011-401-2111	<b>Lithuania</b> 370-2-231-402	<b>Norway</b> 47-66-77-88-99	<b>Poland</b> 48-22-549-0888
<b>Portugal</b> 351-13-877-016	<b>Romania</b> 40-1-311-3479	<b>Slovakia</b> 421-88-415-2011	<b>Slovenia</b> 386-61-161-3270
<b>South Africa</b> 27-11-314-10-89	<b>Spain</b> 34-93-291-0330	<b>Sweden</b> 46-8-5072-5000	<b>Switzerland</b> 41-71-447-0447
<b>Turkey</b> 90-212-281-8181	<b>Ukraine</b> 380-44-238-6908	<b>United K.</b> 44-208-420-8140	
<b>Russia:</b>	<b>Moscow</b> 7-095-926-5509	<b>St. Petersburg</b> 7-812-325-3083	

*For Middle East & African Countries not shown: 33 1 34-40-72-00*